

## 15-AH33B-HFI-24

QTY/CTN: 4



External Top Open Camera housing IP66 with Heater, Fan & IR LED's

### FEATURES

- Heat dissipation with embedded blower
- Automatic defogging glass for best camera view
- Pressure die-cast aluminum construction with light ivory powdered coating & stove finished
- Die-casting aluminum construction, external weatherproof use, IP66
- Patented fully cable managed with swivel bracket**
- DC12V output for camera input
- 3 Way terminal block with 3 Amp fuse, Spare 6 way terminal block
- 11 pcs. IR LED's, Illumination up to 120 meters**
- Size: 160(W) x 165(H) x 425(L) mm
- Heater: 18°C(ON) / 28°C(OFF) / Brower: 35°C(ON) / 25°C(OFF)
- AC24V operation

**\*AC80V~260V input model**

**120M  
Illumination**

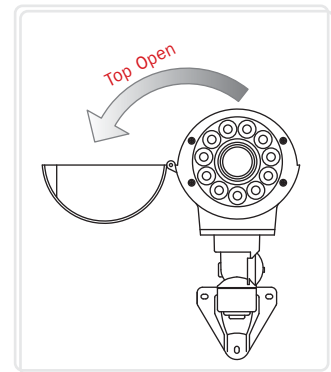
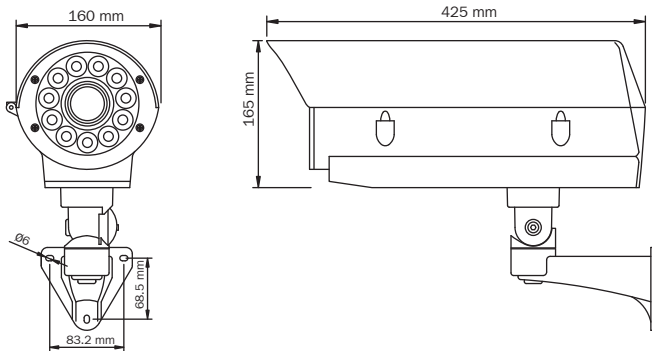

### SPECIFICATION

Items	15-AH33B-HFI-24
Housing Size	425(L) x 160(W) x 165(H)
Max Size Camera	200(L) x 110(W) x 115(H)
Weight	Housing: 3500g (bracket: 630g)
Plate Glass	4
Construction	Die-Case Aluminum
Finish	Ivory powder coating & stove finished
Proposal	Outdoor
Heater	18°C(ON) / 28°C(OFF)
Blower	35°C(ON) / 25°C(OFF)
Power Supply	AC24V
Power Consumption	11 W